

## ANSI 2500 Wafer - Type 26W

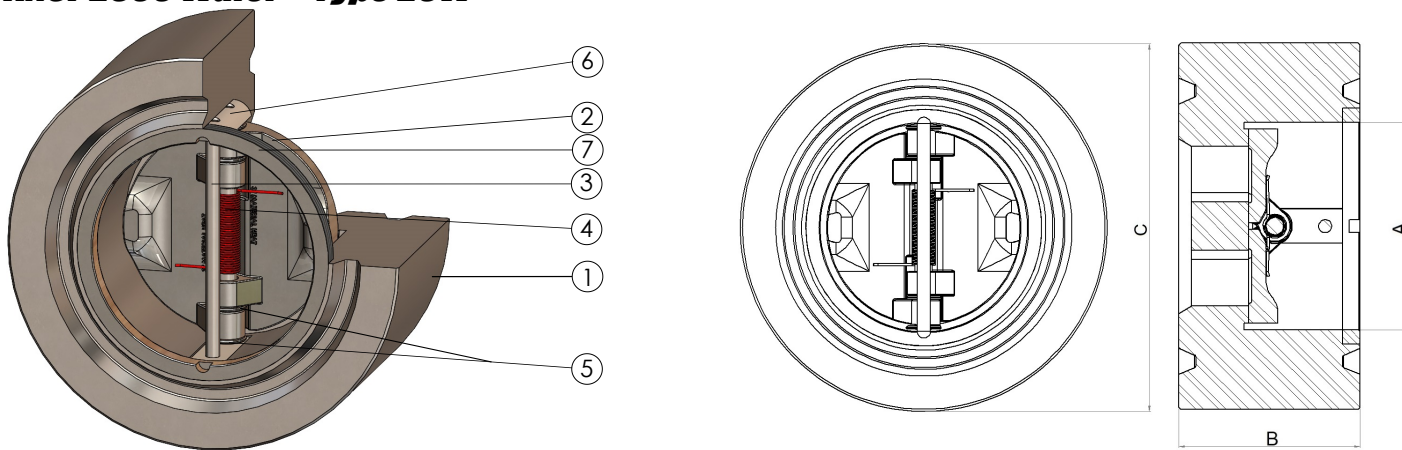

POS.	DESCRIPTION
1	Body
2	Disc
3	Pin
4	Independent spring
5	Spacer ring
6	Carrier
7	Keeper Ring

### VALVES DESIGN

- ACCORDING TO API 594
- SUITABLE FOR ASME B16.5 FLANGES NPS 2" TO 24"
- SUITABLE FOR ASME B16.47 SERIE A FLANGES NPS 26" AND LARGER
- ALTERNATIVE FLANGE COMPLIANCE AVAILABLE UPON REQUEST
- FACE TO FACE DIMENSIONS: API 594
- RETAINERLESS DESIGN
- 3 mm CORROSION ALLOWANCE MINIMUM
- TAGGING AS PER MSS SP-25
- MATERIALS IN ACC. TO ASTM STD.
- MATERIAL IN ACC. TO NACE MR 0175
- PRESSURE TESTING OF 100% OF ALL VALVES SHALL BE CARRIED OUT AND CERTIFIED IN ACCORDANCE WITH API 598
  - Hydro Shell Test @ 1.5 x CWP
  - Hydro Seat Test @ 1.1 x CWP
  - Leakage rates shall be as per API 598.
  - Pneumatic Seat Testing available on request

### MATERIALS

- STAINLESS STEELS
- CARBON STEEL
- LOW TEMPERATURE CARBON STEEL
- SPECIAL ALLOYS, DUPLEX, SUPER DUPLEX
- OVERLAY ON SEATS ON REQUEST
- OTHER MATERIALS ON REQUEST

### CERTIFICATION SHALL BE SUPPLIED AS FOLLOWS (In accordance with EN10204)

Component	Certification
Valve Body	3.1
Valve Disc	3.1
Hinge/Stop Pin	3.1
Spring	3.1
Screw	2.1

### DIMENSIONS & Technical information

Size inches	Pressure Rating ANSI	End Facing	Dimensions			Approx. Weight Kg
			Ø A	B	Ø C	
3	2500	RJ-32	95	86	197	15

\* Dimensions are in mm.

### OFFICIAL APPROVALS

ISO 9001:2008  
PED 2014/68/EU  
ATEX 2014/34/EU  
LR TYPE APPROVAL FOR MARINE APPLICATION CLASS III  
FIRE SAFE CERTIFICATE ACC. TO BS 6755 P.2, API 607, API 6FA  
AND ISO 10497  
TR CU 010 -TR CU 032